

Reliable®

Model E & E3 2½" (65 mm), 3" (80 mm) & 76 mm Sizes Alarm Check Valves With Model E3 Trim

Bulletin 427 January 2019

Features

1. Made expressly for wet-pipe sprinkler systems.
2. Valve's grooved seat design insures positive water flow alarm operation
3. Precision retard chamber limits false alarms under variable pressure conditions
4. External bypass aids in prevention of false alarms under all supply conditions.
5. Vertical and horizontal installation options.
6. Model E3 Valve: 300 psi rated
Model E Valve: 175 psi rated
7. Model E3 Valve: Groove/Groove
Model E Valve: Flange/Flange or Flange/Groove
8. Model E3 Trim is used with both Model E and Model E3 Valves.
9. Galvanized trim styles available:
 - Individual part trim
 - Pre-assembled trim
 - Factory trimmed valve

Approvals and Listings:

1. Listed by Underwriters Laboratories and certified by UL for Canada (cULus)
2. FM Approved (FM)

The Reliable Model E and Model E3 Alarm Check Valve acts as a Water Flow Alarm Device in wet pipe sprinkler systems. The design allows for installation under both variable and constant supply pressure conditions. When water flows into the sprinkler system due to the operation of one or more Automatic Fire Sprinklers the Alarm Valve opens, allowing continuous flow of water into the system and a transmission of an alarm, both electrically and mechanically.

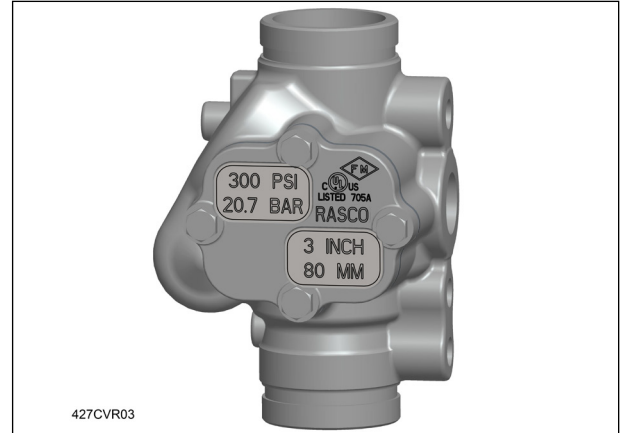

Model E3 Alarm Valve - 300 psi (20.7 Bar) rated Groove/Groove

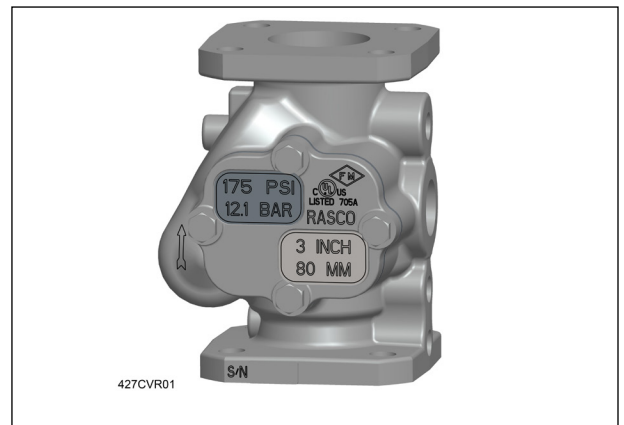

Model E Alarm Valve - 175 psi (12.1 Bar) rated Flange/Flange

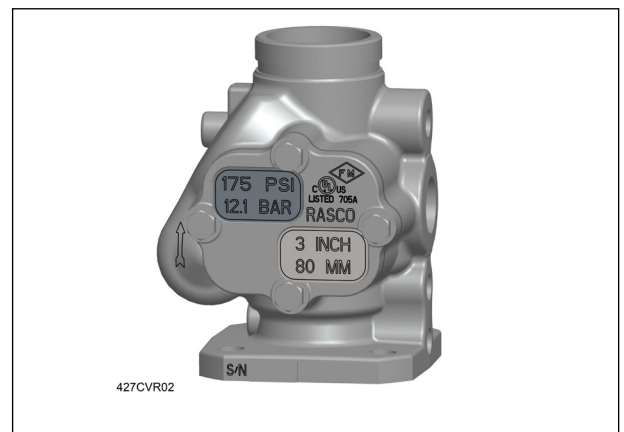

Model E Alarm Valve - 175 psi (12.1 Bar) rated Flange/Groove

Operation

Variable Pressure

The Reliable Model E & E3 Alarm Check Valve in its closed and open positions is shown in Fig. 1 and Fig. 2. The closed position is maintained as long as the water pressure in the sprinkler system piping above the Alarm Valve is greater than, or equal to, the supply pressure. A flow of water into the system piping, resulting from the discharge through one or more fused Automatic Sprinkler(s), causes the Clapper to rise off its Grooved Seat and permits water from the supply to enter the system for distribution on the fire.

Virtually all sprinkler system piping contains confined air. If a water hammer or pressure surge occurs in the supply line, the increased pressure will compress the confined air and cause the Alarm Valve Clapper to lift intermittently which may result in false alarms. The Model E and Model E3 Alarm Check Valve prevents false alarms under these conditions using two features:

- a. The By-Pass connection with Check Valve (Figure 3 & 4) allows pressure surges from the supply to by-pass the Alarm Valve Clapper. An excess system pressure is thus created which steadies the Clapper. Should a heavy surge unseat the Clapper and permit water to flow into the alarm line, the Retard Chamber then comes into action.
- b. Drain Orifice Restriction from / to the Retard Chamber allows intermittent flows to be drained before the Chamber fills and activates the Alarms.

Constant Pressure

The operation of the Model E Alarm Check Valve in installations where the water pressure is constant is the same as described above, with this exception: The Retard Chamber is not required and water passing through the groove in the Alarm Check Valve Seat flows directly to and activates the Mechanical and Electrical Alarms.

Note: 1 bar = 100 kPa

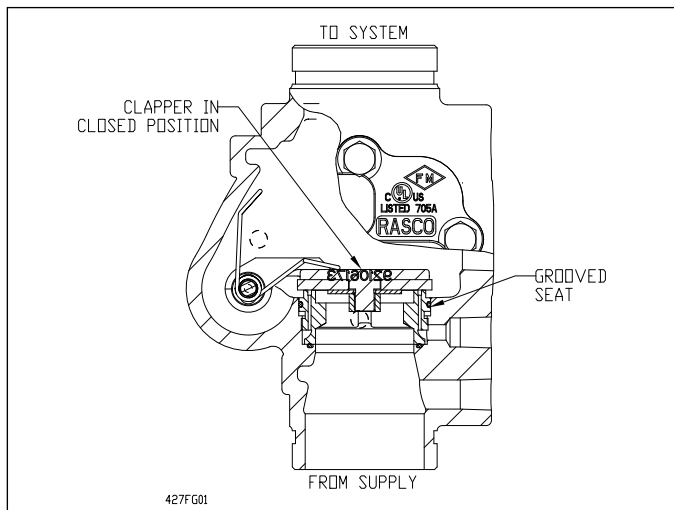

Fig. 1

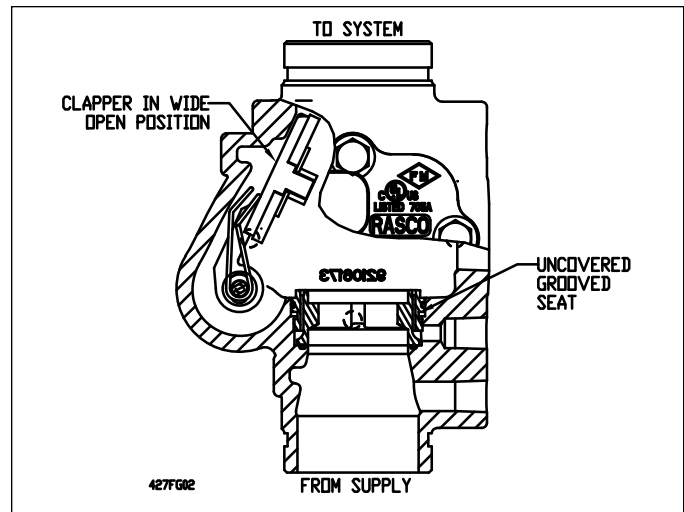

Fig. 2

Valve Description

1. Rated working pressure:
 - Model E valves are rated to 175 psi (12.1 bar)
 - Model E3 valves are rated to 300 psi (20.7 bar)
2. Factory hydrostatic test pressure:
 - Model E valves are tested to 350 psi (24.2 bar)
 - Model E3 valves are tested to 600 psi (41.4 bar)
3. End and Trim connections – Four valve connection styles are available
 - a. Model E valve with US Standard Flanged Inlet and Outlet
 - Flanges mate with ANSI B 16.1 (Class 150) Flange

US Flange Table:

Valve Size:	Bolt Circle Diameter	Bolt Hole Diameter	Square Flange Dimension	Flange Thickness	No. Bolts
2½" (65 mm)	5½" (140 mm)	¾" (19 mm)	6⅞" (156 mm)	¾" (19 mm)	4
3" (80 mm)	6" (152 mm)	¾" (19 mm)	6⅞" (156 mm)	¾" (19 mm)	4

- Threaded openings per ANSI B 2.1
 - Reliable's standard trim sets are compatible with 2½" (65 mm) & 3" (80 mm) US Flanged Valves
 - Color - Black
- b. Model E valve with US Standard Flanged Inlet and Grooved Outlet (Fig. 1)
 - Inlet flange mates with ANSI B 16.1 (Class 150) Flange
 - Outlet groove dimensions per ANSI/AWWA C606

Groove Dimension Table

Valve Size:	Outlet Diameter	Groove Diameter	Groove Width	Outlet Face to Groove
2½" (65 mm)	2.875" (73 mm)	2.720" (69 mm)	11/32" (9.0 mm)	5/8" (16 mm)
76 mm	3.000" (76 mm)	2.845" (72 mm)	11/32" (9.0 mm)	5/8" (16 mm)
3" (80 mm)	3.500" (89 mm)	3.344" (85 mm)	11/32" (9.0 mm)	5/8" (16 mm)

- Threaded openings per ANSI B 2.1
- Reliable's standard trim sets are compatible with

2½" (65 mm) & 3" (80 mm) US Flanged Valves

- Color - Black

c. Model E valve with Metric flanged inlet and outlet Flanged Inlet and Outlet

- 65 mm valve plain faced flanges mate with DIN 2500 8.66, NF-E-29-282 and BS 4504 NP16 Flanges

Metric Flange Table (mm):					
Valve Size:	Bolt Circle Diameter	Bolt Hole Diameter	Square Flange Dimension	Flange Thickness	No. Bolts
65 mm	145 mm	18 mm	156 mm	19 mm	4

- Threaded openings per ANSI B 2.1
- Reliable's standard trim sets may be used with metric valves provided trim is assembled carefully and extra thread sealant is applied to the connections between valves and trim.
- Color - Red

d. Model E3 valve with Grooved End Connections

- 2½" (65 mm), 3" (80 mm) & 76 mm inlet and outlet groove dimensions per ANSI/AWWA C606 (See table above)
- Threaded openings per ANSI B 2.1
- Reliable's standard trim sets are compatible with 2½" (65 mm) & 3" (80 mm) & 76 mm Grooved Valves
- Color - Black (2½" & 3") or Red (65 mm, 80 mm

and 76 mm)

4. Face to Face Dimensions:

Face to Face Dimension Table:		
Valve Size:	End Connection:	End to End Dimension:
2½" (65 mm), 76 mm & 3" (80 mm)	Flange/ Flange	9 ³ / ₁₆ (233)
	Flange/ Groove	9 ³ / ₁₆ (233)
	Groove/ Groove	10¼ (260)

5. Shipping Weight:

Valve Shipping Weight Table:		
Valve Size:	End Connection:	Weight lb(kg):
2½" (65 mm), 76 mm & 3" (80 mm)	Flange/ Flange	35.0 (15.9)
	Flange/ Groove	32.0 (14.5)
	Groove/ Groove	26.5 (12.0)

Trim Shipping Weight Table:	
Trim Type:	Weight lb(kg):
Horizontal Trim	17.0 (7.7)
Vertical Trim	16.0 (7.3)
Retard Chamber	4.0 (1.8)

6. Friction Loss – Expressed in Equivalent Length of Pipe, Based on Hazen & Williams Formula

Friction Loss Table		
Valve Size:	Equivalent Length ft(m)	
	C=100	C=120
2½" (65 mm) & 76 mm	5.5 (1.7)	7.7 (2.4)
3" (80 mm)	15.3 (4.7)	21.5 (6.6)

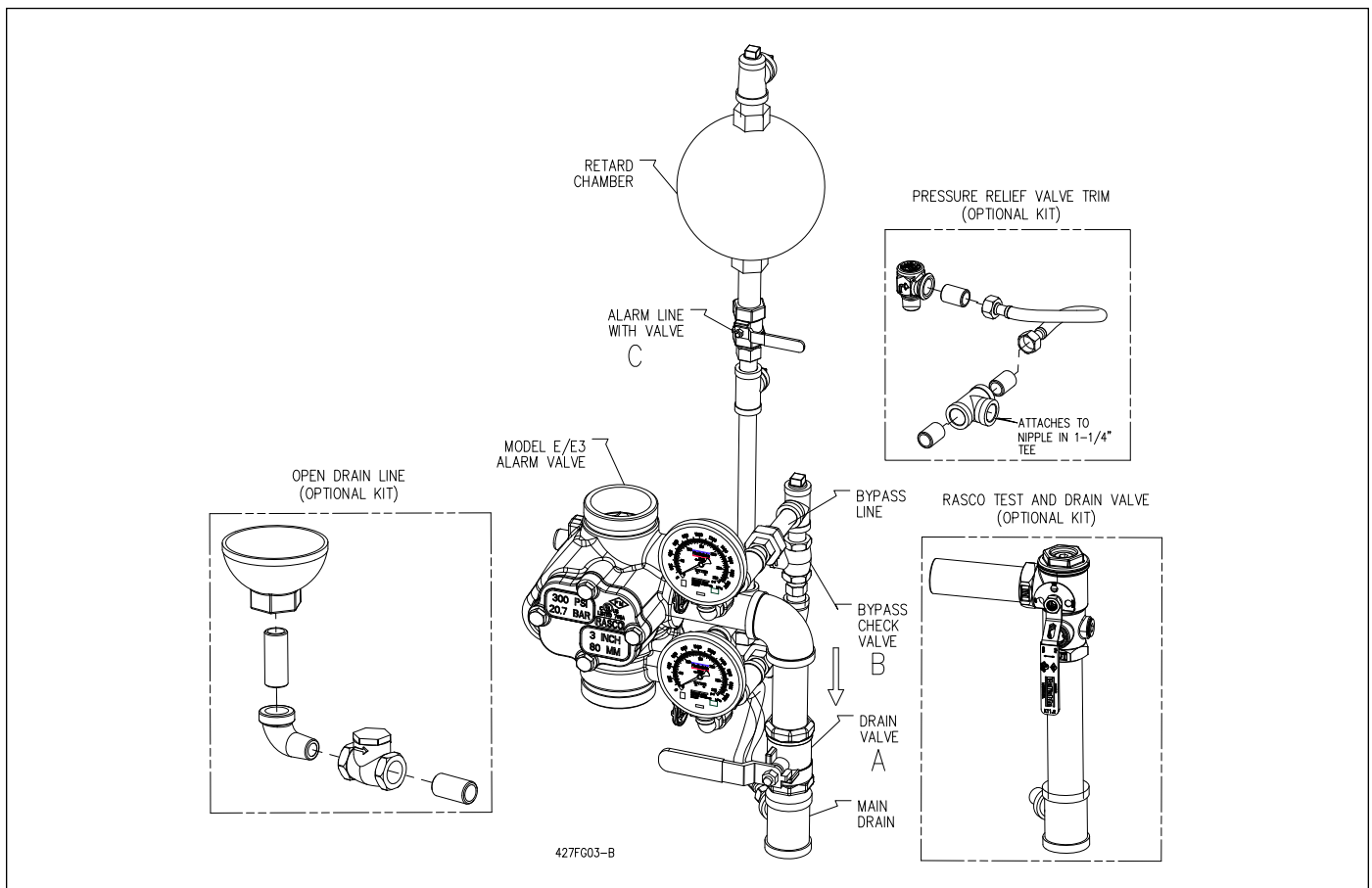

427FG03-B

Fig. 3 - Vertical Trim

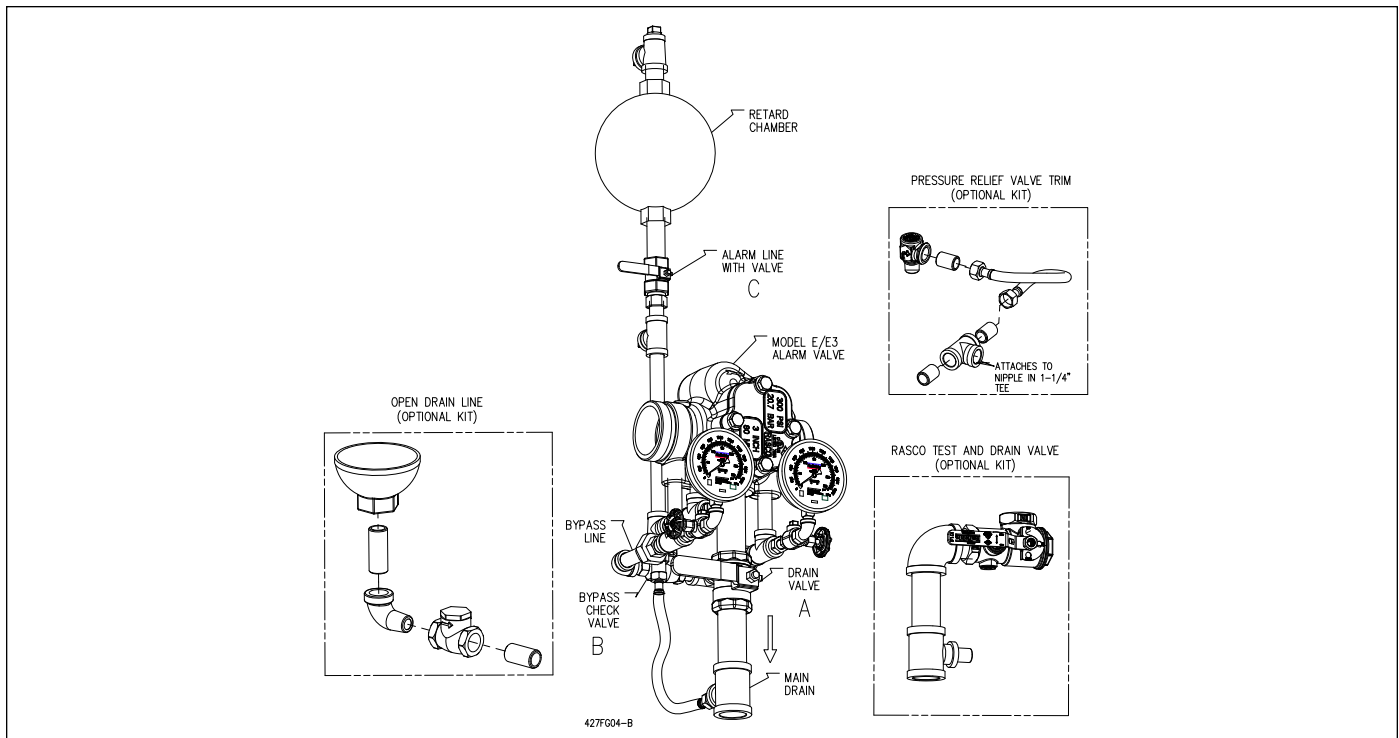

Fig. 4 - Horizontal Trim

Model E3 Trim Description

The E3 trim sets for the Reliable Model E and Model E3 Alarm Valve (Figs. 3 & 4) are arranged for rapid, easy and compact attachment, and serve as connection points to Reliable alarm and other devices. They also act as a means for testing system operation. The Model E and E3 Alarm Valves are available with separate trim configurations for either vertical or horizontal installation and the following options:

- Constant Pressure, Closed Drain - Retard Chamber is not required. The Model E3 trim is available as a constant pressure trim. This trim set is used where water supply pressure does not vary, such as a gravity tank. The mechanical sprinkler alarm line automatically drains to the 1/4" (32 mm) main drain line.
- Variable Pressure with Closed Retard Chamber Drain—Retard Chamber is required. This trim is used where water supply pressures vary. A closed drain is provided to drain the Retard Chamber and the Mechanical Sprinkler Alarm line. The mechanical sprinkler alarm line automatically drains to the 1/4" (32 mm) main drain line.
- Variable Pressure with Open Retard Chamber Drain—Retard chamber is required. Optional Drain Line Kit required (see Figs. 3 & 4). This trim set is used where water supply pressures vary. An open drip cup is provided to drain the retard chamber and the mechanical sprinkler alarm line. This drain connection is piped directly into the 1/4" (32 mm) main drain line.
Note: A combination test and drain valve segment is optional, to be purchased separately, as a replacement to the Drain valve (see optional Kit in Figs. 3 & 4).

- Pressure Relief Trim Kit — Required with a wet systems to be installed in accordance with the 2010 edition (and newer) of NFPA 13. For convenience, an optional pressure relief valve kit (illustrated in Figs. 3 and 4) is available. **Note:** Pressure relief trim is not intended for use in relieving water hammer or fire pump surges.

Trim Kits are available in three assembly options:

- Individual part trim
- Pre-assembled trim
- Factory trimmed valve

Ordering Information

Specify:

- Valve Size—[2-1/2"][3"][65 mm][76 mm][80 mm].
- Valve Type and Inlet/Outlet Connections: [Model E valve Flanged/Flanged 175 psi (12.1 bar) rated][Model E valve Flanged/Grooved 175 psi (12.1 bar) rated][Model E3 valve Grooved/Grooved 300 psi (20.7 bar) rated].
- Type of Trim—Constant Pressure or Variable Pressure/Closed Drain or Variable Pressure/Open Drain.
- Installation Orientation: [Vertical][Horizontal].
- Trim Style: [Individual Part Trim][Pre-assembled Trim][Factory Trimmed Valve].
- Additional Equipment—Retard Chamber, Mechanical Sprinkler Alarm, Pressure Relief Trim Kit, and Pressure Alarm Switch must be separately ordered.

Installation Dimensions in Inches (mm)																			
A	B	C	D	E	F	G*	G**	H	I	J	K	L	M	N	O	P	Q	R	S
4¼ (108)	9 (229)	10 (254)	4¾ (121)	12¾ (324)	21¼ (540)	10¼ (260)	9 ³ / ₁₆ (233)	17 (432)	16½ (419)	10¾ (273)	7¼ (184)	15 (381)	23½ (597)	4¾ (121)	6 (152)	4¾ (121)	3 (76)	8¼ (210)	9¼ (235)

G* is total takeout for Grv/Grv Valve Configurations

G** is total takeout for Flg/Grv and Flg/Flg Valve Configurations

Vertical Variable Trim - Top View

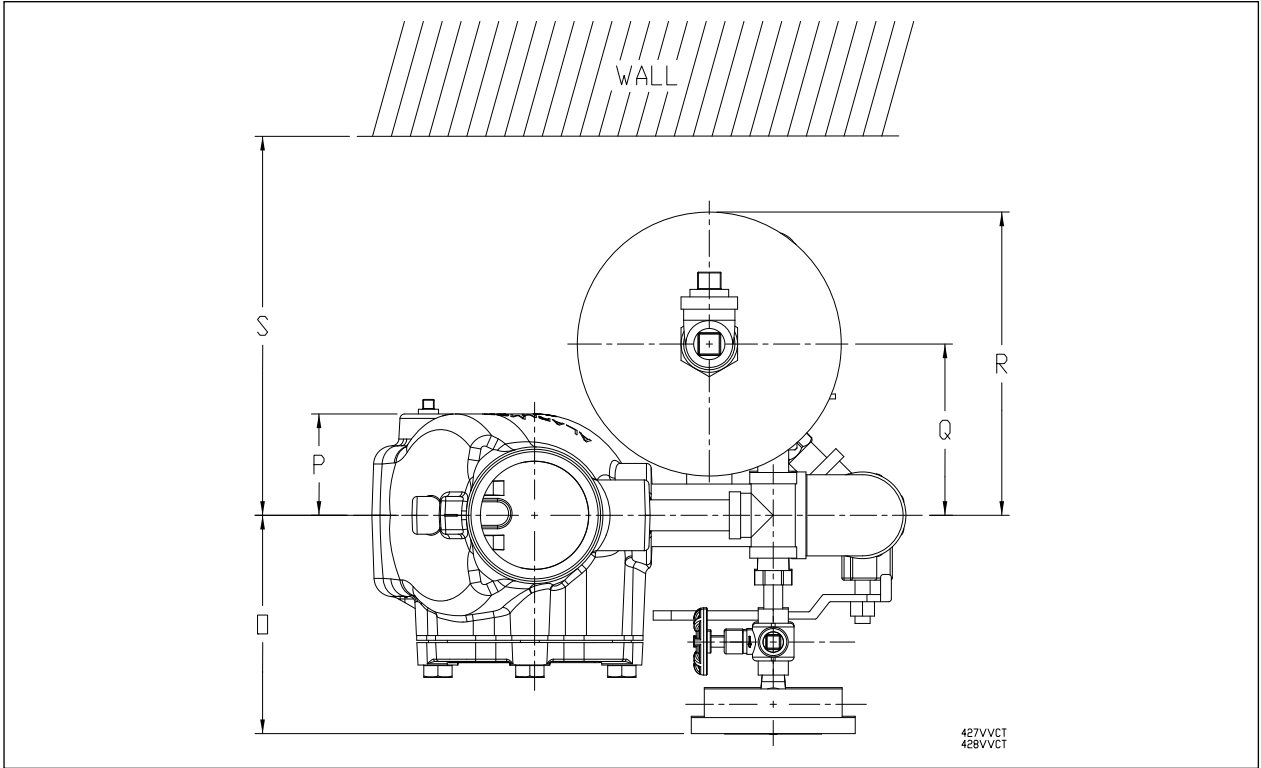

Horizontal Variable Trim - Top View

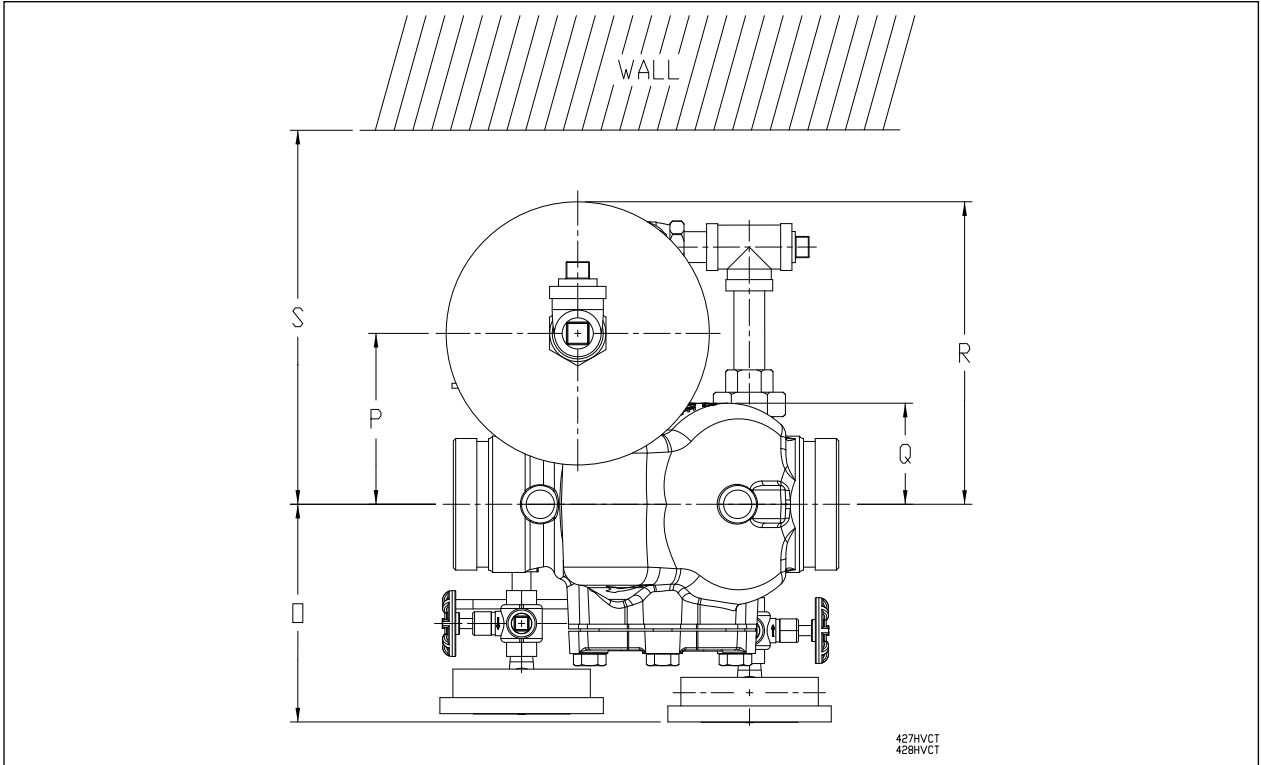

Vertical Variable Trim - Front Elevation

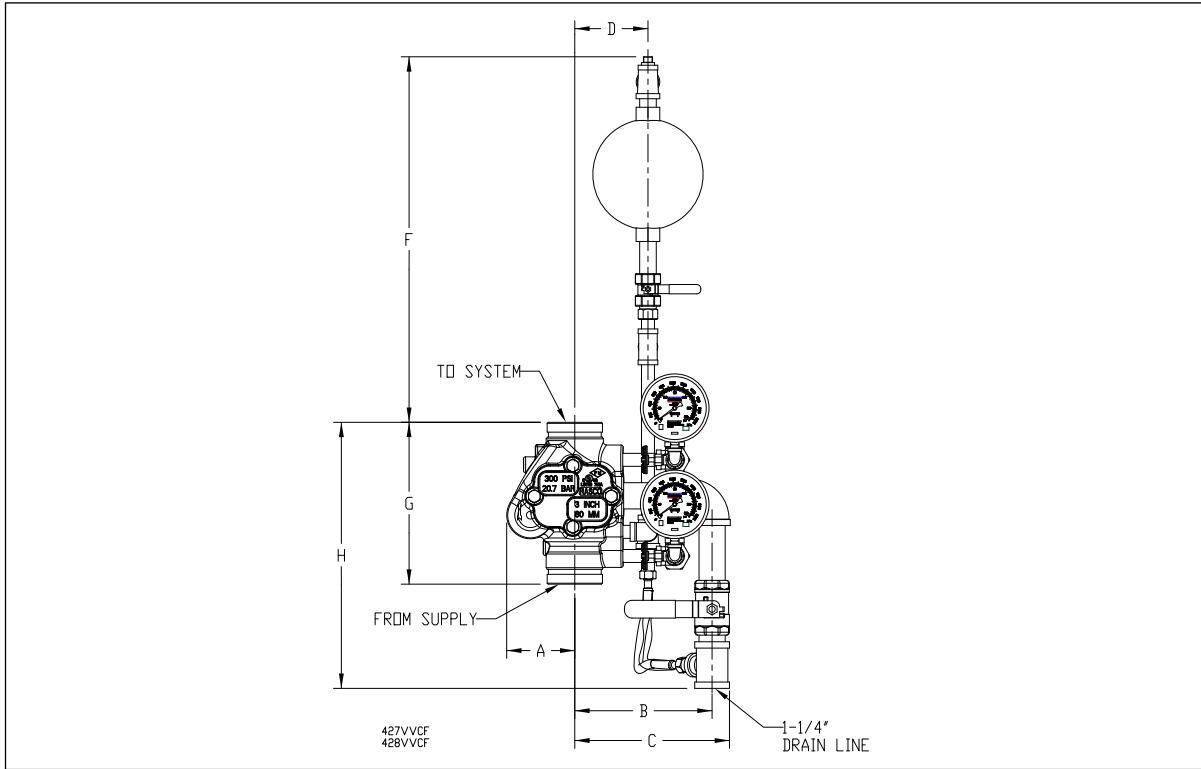

Horizontal Variable Trim - Front Elevation

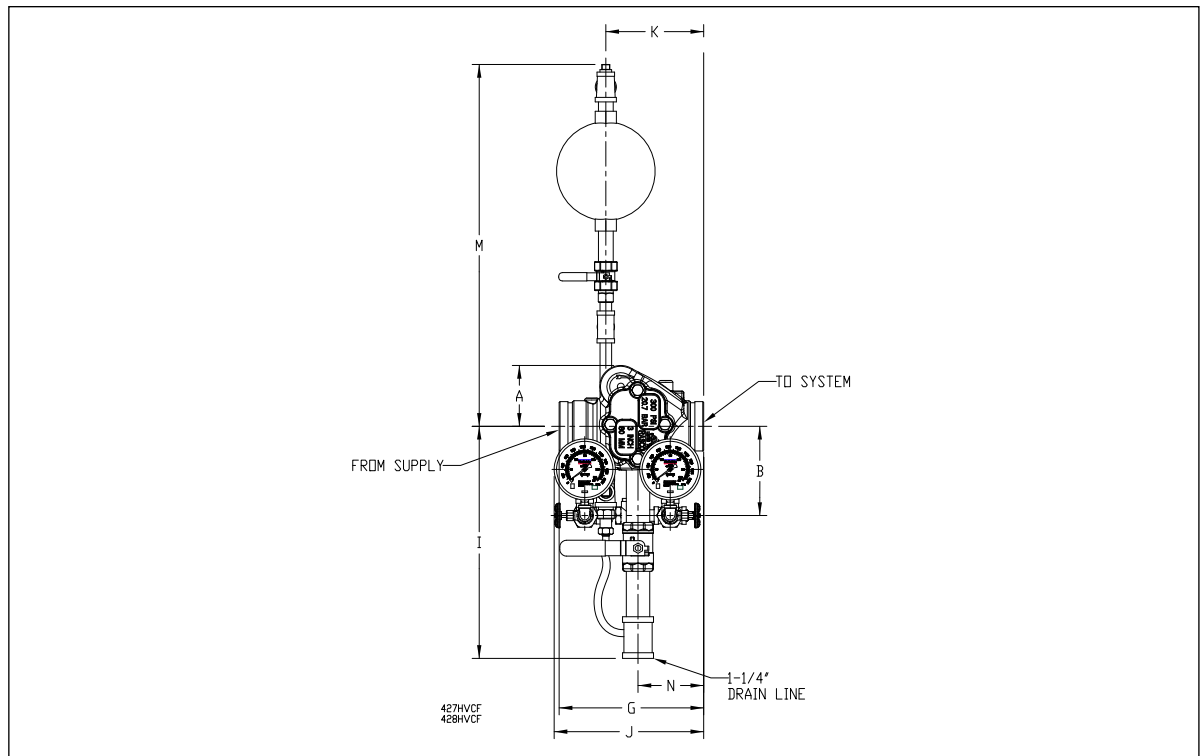

Vertical Constant Trim - Front Elevation

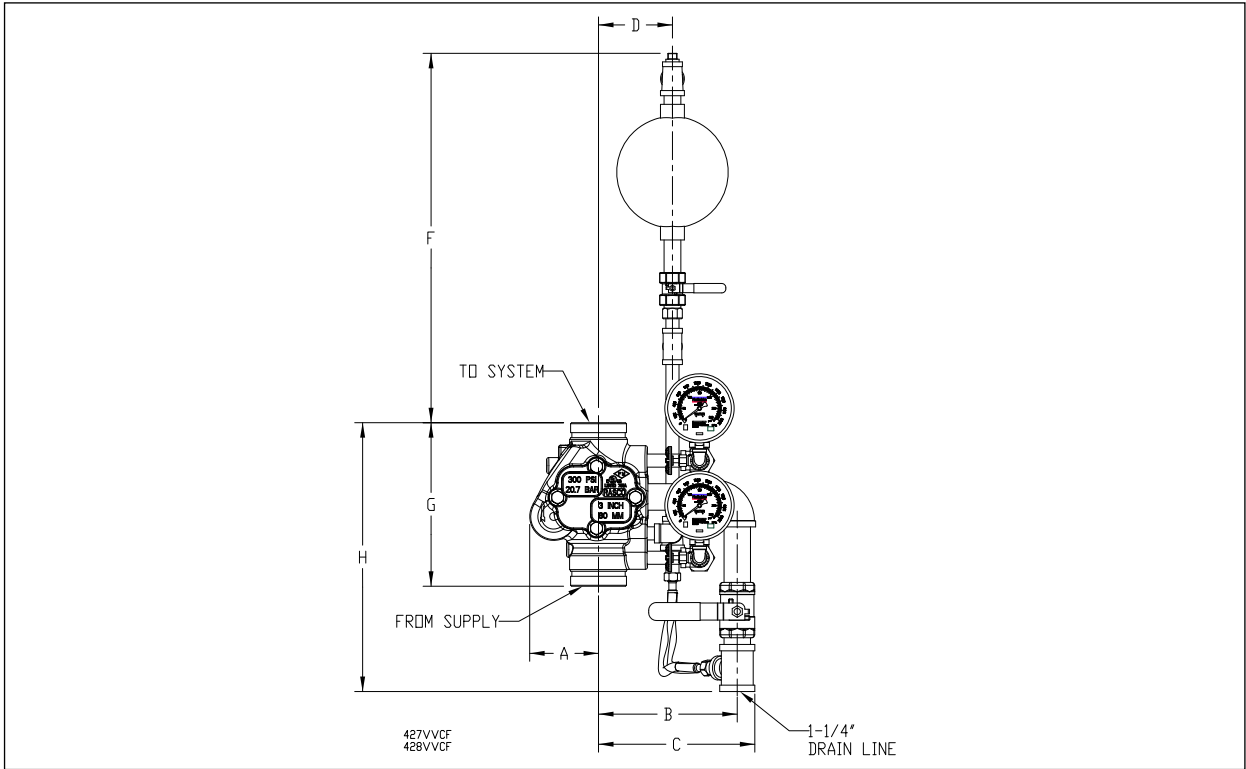

Horizontal Constant Trim - Front Elevation

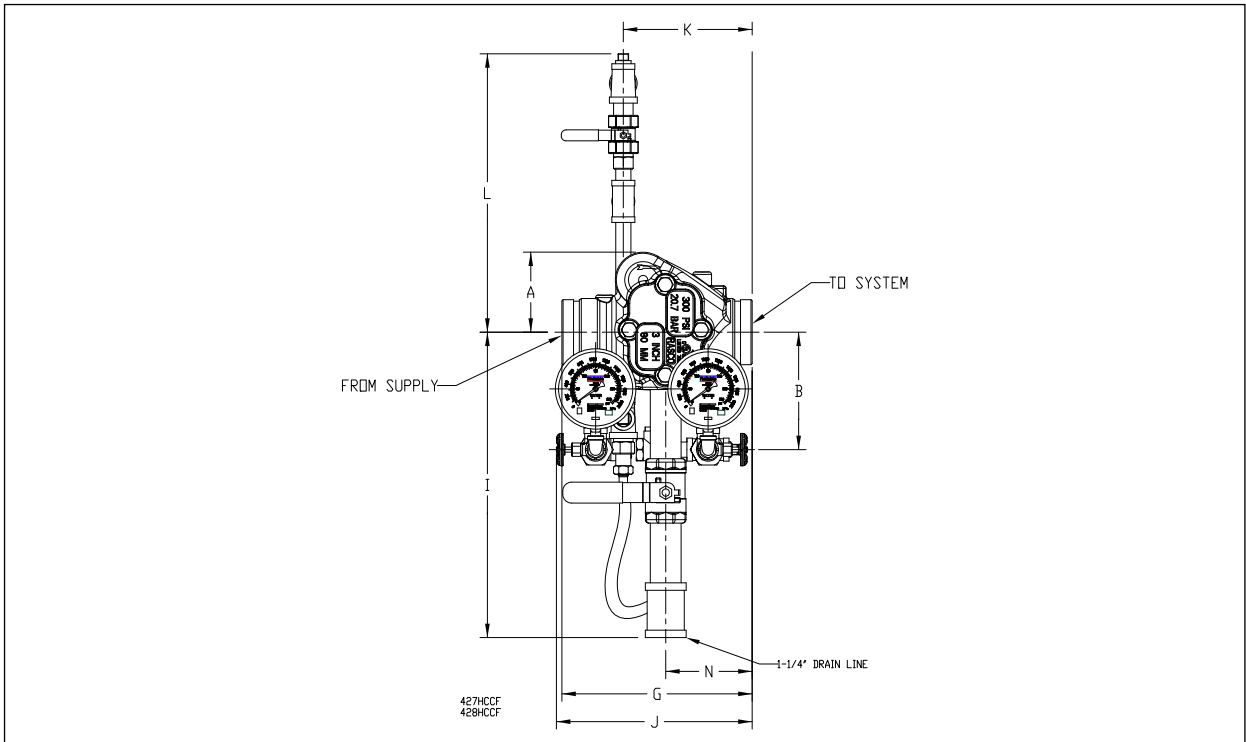

The equipment presented in this bulletin is to be installed in accordance with the latest published Standards of the National Fire Protection Association, Factory Mutual Research Corporation, or other similar organizations and also with the provisions of governmental codes or ordinances whenever applicable.

Products manufactured and distributed by Reliable have been protecting life and property for over 90 years.

Manufactured by



Reliable Automatic Sprinkler Co., Inc.

(800) 431-1588 Sales Offices
 (800) 848-6051 Sales Fax
 (914) 829-2042 Corporate Offices
 www.reliablesprinkler.com Internet Address



Revision lines indicate updated or new data.