

Reliable®

Model JL14 & JL17 ESFR Pendent Sprinklers

175 psi (12 bar) rated

Features

- cULus, VdS, and LPCB listed as an ESFR sprinkler
- FM Approved as a quick-response, storage and non-storage sprinkler
- Fusible link operating element
- Compact design

Product Description

The Reliable Models JL14 and JL17 are Early Suppression Fast Response (ESFR) Sprinklers with nominal K-factors of 14.0 (200 metric) and 16.8 (240 metric), respectively. The sprinklers use a levered fusible alloy solder link in either a 165°F (74°C) or a 212°F (100°C) temperature rating. These sprinklers are designed to respond quickly to growing fires and will deliver a heavy water discharge to “suppress” rather than “control” fires.

FM Approvals classifies the Model JL14 and JL17 as quick-response sprinklers, storage and non-storage, when used in accordance with FM Global Property Loss Prevention Data Sheets.

The JL14 and JL17 sprinklers are available with 3/4" NPT or ISO7-1R3/4 (BSPT) threads, and the JL17 is also available with the Victaulic® IGS™ Style V9 Sprinkler Coupling*.

Model JL14 and JL17 ESFR sprinklers are designed to be shorter and more compact than other ESFR sprinklers, allowing greater flexibility with regard to distance from ceilings and obstructions. The JL14 and JL17 ESFR sprinklers are also less susceptible to damage due to smaller deflector and frame design. The lighter JL14 and JL17 ESFR sprinklers passed rough use and abuse listing tests without plastic protectors

***Note:** Victaulic® and IGS™ are trademarks of Victaulic Company.



Models JL14 & JL17 ESFR Pendent Sprinklers

Table A

Model	Nominal K-factor gpm/psi ^{1/2} (L/min/bar ^{1/2})	Approvals	Sprinkler Identification Number (SIN)
JL14	14.0 (200)	cULus, FM, VdS, LPCB, CNBOP-PIB	RA1812
JL17	16.8 (240)	cULus, FM, VdS, LPCB, CNBOP-PIB	RA1914

Technical Specifications

Style: Pendent
Connection: 3/4" NPT or ISO7-1R3/4 (BSPT) threads
Nominal K-Factor: 14.0 (200 metric)
Max. Working Pressure: 175 psi (12 bar)

Material Specifications

Thermal Sensor: Beryllium Nickel Solder Link
Sprinkler Frame: Brass Alloy
Cap: Bronze Alloy
Sealing Assembly: Nickel Alloy with PTFE
Load Screw: Bronze Alloy
Deflector: Bronze Alloy
Kick Spring: Stainless Steel Alloy

Sprinkler Finishes

Bronze

Sensitivity

Fast-Response
 Quick-Response (FM)

Temperature Ratings

Ordinary: 165°F (74°C)
 Intermediate: 212°F (100°C)

Sprinkler Wrench

Model J1

Guards & Shields

Model S-3 Water Shield (FM)*

Listings and Approvals

cULus
 FM Approved
 VdS
 LPCB
 CNBOP-PIB



***Note:** Model JL14 fire sprinkler is FM Approved with Model S-3 Water Shield for use as a pendent intermediate level sprinkler. Model S-3 Water Shield diameter is 3-3/4" (95mm).

Model JL14 Sprinkler Components and Dimensions

Figure 1

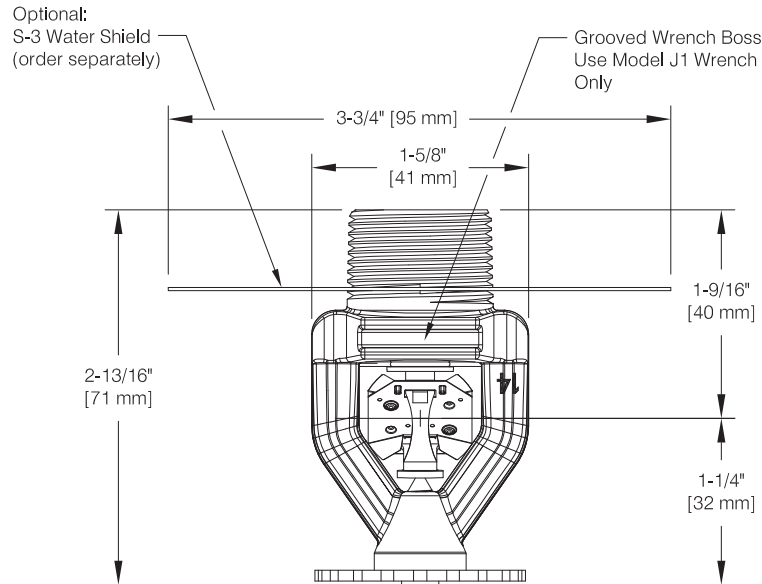

Technical Specifications

Style: Pendent
Connection: 3/4" NPT or ISO7-1R3/4 (BSPT) threads, Victaulic® IGS™ Style V9 Sprinkler Coupling
Nominal K-Factor: 16.8 (240 metric)
Max. Working Pressure: 175 psi (12 bar)

Material Specifications

Thermal Sensor: Beryllium Nickel Solder Link
Sprinkler Frame: Brass Alloy
Cap: Bronze Alloy
Sealing Assembly: Nickel Alloy with PTFE
Load Screw: Bronze Alloy
Deflector: Bronze Alloy
Kick Spring: Stainless Steel Alloy

Sprinkler Finishes

Bronze

Sensitivity

Fast-Response
 Quick-Response (FM)

Temperature Ratings

Ordinary: 165°F (74°C)
 Intermediate: 212°F (100°C)

Sprinkler Wrench

Model J1

Guards & Shields

Model S-3 Water Shield (FM)*

Listings and Approvals

cULus
 FM Approved
 VdS
 LPCB
 CNBOP-PIB



***Note:** Model JL17 fire sprinkler is FM Approved with Model S-3 Water Shield for use as a pendent intermediate level sprinkler. Model S-3 Water Shield diameter is 3-3/4" (95mm).

Model JL17 Sprinkler Components and Dimensions

Figure 2

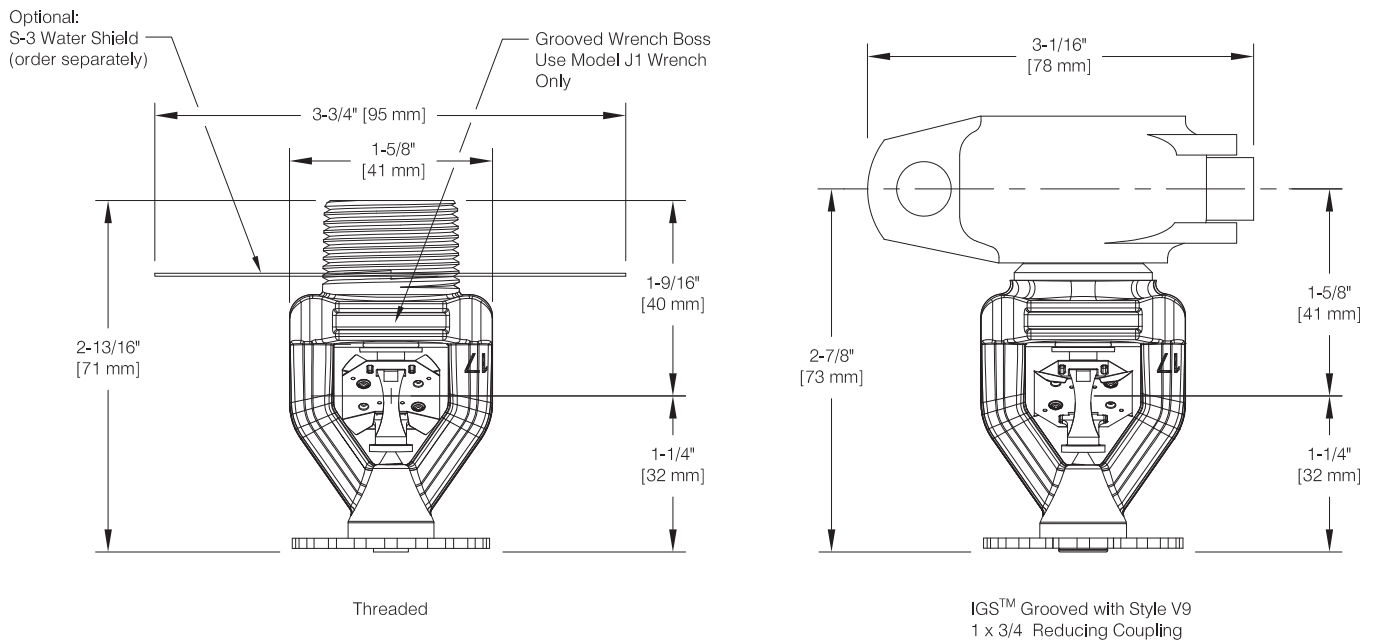

Model JL14 and JL17 Commodity Selection and Design Criteria Overview

Table B

Storage Type	NFPA	FM GLOBAL
Sprinkler Type	ESFR	Storage
Response Type	ESFR	Quick Response
System Type	Wet	Wet
Temperature Rating °F (°C)	165 (74), 212 (100)	165 (74), 212 (100)
Roof Construction	See NFPA 13	See FM Global 2-0
Ceiling Slope	See NFPA 13	See FM Global 2-0
Maximum Coverage Area	See NFPA 13	See FM Global 2-0
Minimum Coverage Area	See NFPA 13	See FM Global 2-0
Maximum Spacing	See NFPA 13	See FM Global 2-0
Minimum Spacing	See NFPA 13	See FM Global 2-0
Minimum Clearance to Commodity	See NFPA 13	See FM Global 2-0
Sprinkler Distance to Ceiling	See NFPA 13	See FM Global 2-0
Open Frame, Single, Double, Multiple Row, or Portable Rack Storage of Class I-IV Commodities and Group A Plastics	See NFPA 13	See FM 2-0 & 8-9
Solid Pile or Palletized Storage of Class I-IV Commodities and Group A Plastics	See NFPA 13	See FM 2-0 & 8-9
Idle Pallet Storage	See NFPA 13	See FM 2-0, 8-9 & 8-24
Rubber Tire Storage	See NFPA 13	See FM 2-0 & 8-3
Rolled Paper Storage	See NFPA 13	See FM 8-21
Flammable Liquid Storage	See NFPA 30	See FM 7-29
Aerosol Storage	See NFPA 30B	See FM 7-31
Auto Components in Portable Racks	N/A	N/A

Installation

Model JL14 and JL17 sprinklers are intended for installation in accordance with NFPA 13 and FM Loss Prevention Data Sheets 2-0 and 8-9, as well as the requirements of any Authorities Having Jurisdiction. See Table B for information on NFPA and FM Global design criteria for the Model JL14 and JL17 sprinklers.

For threaded sprinklers only, use the Model J1 sprinkler wrench for removal and installation. Any other type of wrench may damage the sprinkler. A grooved wrench boss is provided on the sprinkler to limit the potential for the wrench to slip during installation.

When handling sprinklers, hold sprinklers only on frame arms and do not apply any force on the link assembly. Model JL14 and JL17 sprinklers should be tightened between 14 - 40 ft-lbs (19 - 54 N-m) torque. Sprinklers not tightened to recommended torque may cause leakage or impairment of the sprinkler. Damaged sprinklers must be replaced immediately.

For grooved sprinklers, push the IGS™ Style V9 Sprinkler Coupling onto the grooved outlet until contact with the center leg of the gasket occurs. Align the sprinkler frame arms and the pads of the coupling with the sprinkler piping and tighten the coupling until the pads of the coupling meet. For additional information, please reference Victaulic® technical bulletin I-V9.

Caution: When handling sprinklers, hold sprinklers only by the frame arms and do not apply any force on the link assembly.

Maintenance

Model JL14 and JL17 ESFR Sprinklers should be inspected and the sprinkler system maintained in accordance with NFPA 25. Do not clean sprinkler with soap and water, ammonia or any other cleaning fluid. Replace any sprinkler that has been painted (other than factory applied) or damaged in any way. A stock of spare sprinklers should be maintained to allow quick replacement of damaged or operated sprinklers. Prior to installation, sprinklers should be maintained in the original cartons and packaging until used, to minimize the potential for damage to sprinklers that would cause improper operation or non-operation.

Once operated, automatic sprinklers cannot be reassembled and reused. New sprinklers of the same size, type and temperature rating must be installed. A cabinet of replacement sprinklers should be provided for this purpose.

Listings and Approvals

1. UL Listed and ULC Certified for Canada (cULus)
2. FM Approved (FM)
3. VdS Certified (VdS)
4. Loss Prevention Certification Board Approved (LPCB)
5. CNBOP-PIB Technical Approval (CNBOP-PIB)



Note: 1" S/142 IGS™ grooved welded outlets are also available from Reliable.



Victaulic® IGS™ Style V9 Sprinkler Coupling installation bit - One bit provided in each box of 25 sprinklers.

Model J1 Sprinkler Wrench

Figure 3



Guarantee

For the Reliable Automatic Sprinkler Co., Inc. guarantee, terms, and conditions, visit www.reliablesprinkler.com.

Ordering Information

Specify

- Sprinkler: [JL14] [JL17]
- Temperature Rating: [165°F (64°C)] [212°F (100°C)]
- End Connection: [3/4" NPT] [ISO7-1R3/4 (BSPT)]
[*JL17 only* Victaulic® IGS™ Style V9 Sprinkler Coupling]

Optional

- S-3 Water Shield (threaded sprinklers only)